

SITE REQUIREMENTS

TCR1S & TCR1X

HUNTER REVOLUTION™ TIRE CHANGER



TCR1X



TCR1S / TCR1X	
Power Requirements	208-230V, 1 phase, 60Hz, 24A, NEMA 30 amp plug, L6-30P, 5,520 watts
Air Supply Requirements	125 ± 25 psi (8.6 ± 1.7 bar)
Air Consumption	1 SCFM (27 L/Min)
Shipping Weight	1,856 lbs (842 kg)
Width (W)	52 in. (1,321 mm)
Height (H1)	TCR1S: 78.5 in. (1,994 mm), TCR1X: 86 in. (2,184 mm)
Height (H2)	75.5 in. (1,918 mm),
Depth (D)	67 in. (1,702 mm) - Wheel Lift Up 78 in. (1,981 mm) - Wheel Lift Down

KEY SPECIFICATIONS

TCR1S / TCR1X	
Mount / Demount Tool	Polymer Self Inserting Leverless
Clamping Type	Center w/ Quick Clamp
Bead Loosening Type	Upper / Lower Roller
Match Mounting Capable	Yes
Rim Diameter Range	12 in. - 30 in. (305 mm - 762 mm)
Maximum Tire Diameter	50 in. (1,270 mm)
Maximum Wheel Width	15 in. (381 mm)
Drive	Variable up to 15 rpm CW / CCW Torque: 875 ft-lbs (1186 Nm)

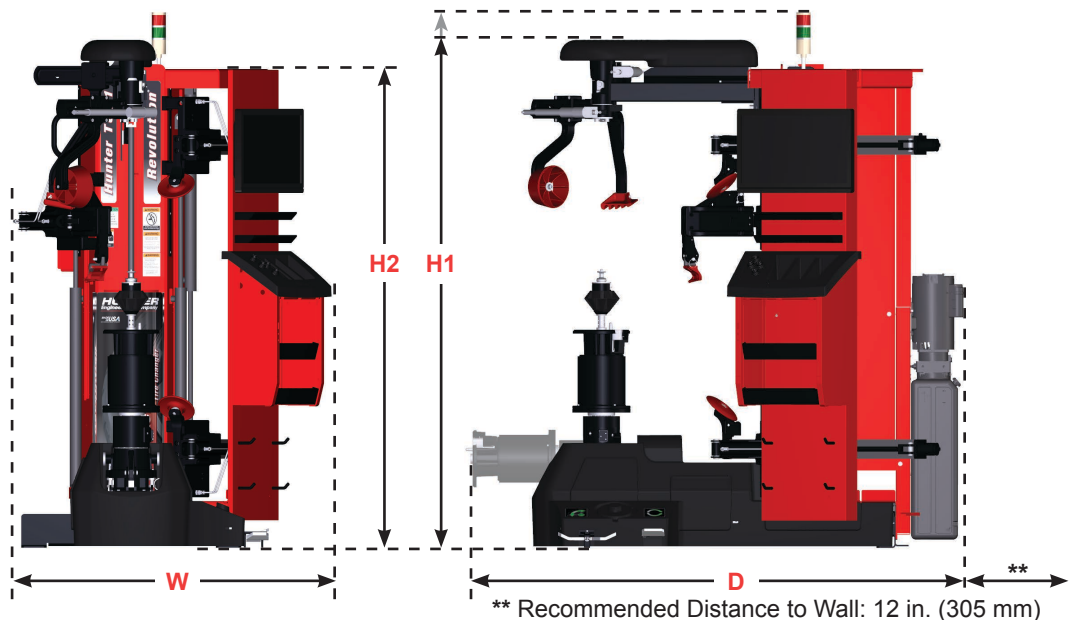

For tire changer information visit:
www.hunter.com/tire-changers

For local contact visit:
www.hunter.com/contact-hunter

For general inquiries visit:
www.hunter.com or call 800-448-6848